

# ZG3225LC-9C HYDRAULIC EXCAVATOR SPECIFICATIONS



## 1. 产品简介 Introduction:

配备康明斯发动机，动力强劲、高效节能、可靠耐用；先进的负流量液压系统，操作舒适，作业效率高，性价比极佳；全功率控制，四种功率模式适应不同工况；步进电机精确控制油门，显著降低油耗；全三维建模和有限元分析技术，保证了结构件的可靠性和稳定性。

Equipped with Cummins engine, strong power, high efficiency, energy saving, reliable and durable; advanced negative flow hydraulic system, comfortable operation, high operating efficiency, excellent cost performance; full power control, four power modes to adapt to different working conditions; stepper motor accurately controls the throttle , Significantly reduce fuel consumption; full 3D modeling and finite

element analysis technology to ensure the reliability and stability of structural parts.

## 2. 性能特点 Characteristics:

(1) 配备康明斯发动机，高耐负荷、大马力输出，可靠性高、油耗低，显著降低使用和维护成本。

Equipped with Cummins engine, high load resistance, high horsepower output, high reliability, low fuel consumption, significantly reduce the use and maintenance costs

(2) 采用先进的负流量液压系统，系统稳定性、可靠性更好，复合动作速度更快，作业效率更高。

Advanced negative flow hydraulic system is adopted, which has better system stability and reliability, faster compound action speed and higher operating efficiency.

(3) 高强度的加强型箱型侧梁和 X 型中框架，高可靠性的拖链轮、支重轮，能承受超大负荷引起的冲击。

High-strength reinforced box-type side beams and X-shaped middle frames, high-reliability towline wheels and track rollers, can withstand the impact caused by excessive loads.

(4) 智能化的电子监控系统，实时监测，自诊断故障报警、维护保养信息提示。

Intelligent electronic monitoring system, real-time monitoring,  
self-diagnosing fault alarm, maintenance information prompt.

(5) LC 型加强履带，强度高、耐磨损，整机作业更加安全稳定。

The LC-type reinforced track has high strength and abrasion resistance,  
making the whole machine safer and more stable.

### 3、Overall Dimension 整机尺寸

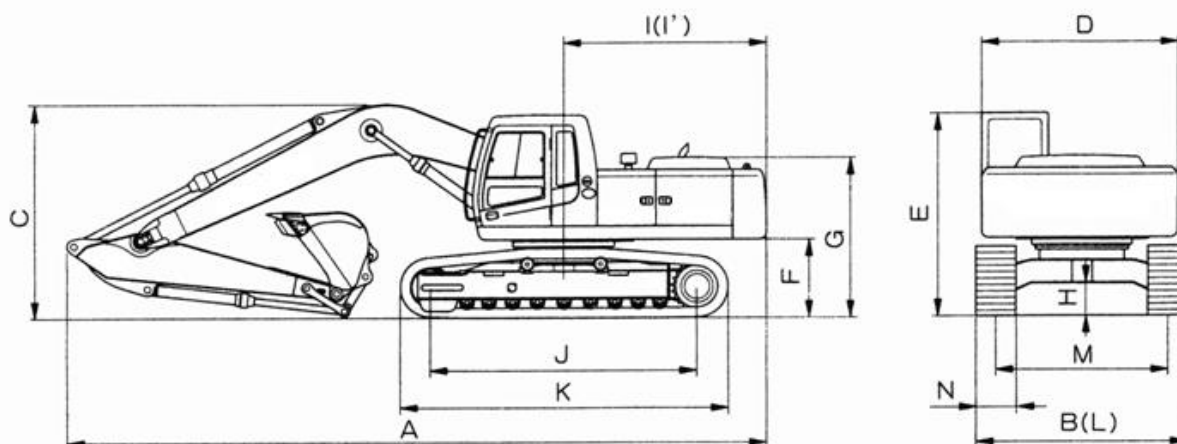

名称 ITEM		单位 UNIT	技术规格 Specifications
			ZG3225LC-9C
操作重量 Operating weight		Kg	22000
标配斗容(加强斗) Rated bucket capacity		m <sup>3</sup>	1.1
总长 Overall length	A	mm	9520
总宽 (600mm 履带) Overall width (600mm track shoe)	B	mm	2990
总高 Overall height	C	mm	3030
转台宽度 Turnable width	D	mm	2700
驾驶室离地高 Cabin height	E	mm	2961
配重离地间隙 Groundclearance of counterweight	F	mm	1028
发动机罩高 Engine cover height	G	mm	2341
最小离地间隙 Min. ground clearance	H	mm	470
转台尾端长度 Tail length	I	mm	2800
尾端回转半径 Turning radius of turnable	I'	mm	2800
履带轴距 Wheel base of track shoe	J	mm	3650
底盘长度 Chassis length	K	mm	4440
底盘宽度 Chassis width	L	mm	2990
履带轨距 Track shoe gauge	M	mm	2390
标配履带宽度 Standard track shoe width	N	mm	600
最大牵引力 Max. traction		KN	204

行走速度 (高/低) Travelling speed (H/L)		Km/hr	5.8/3.3
回转速度 Swing speed		rpm	13.9
爬坡能力 Gradeability		Degree(%)	35 (70%)
接地比压 Ground pressure		Kgf/cm <sup>2</sup>	0.45

#### 4、工作范围 Working range

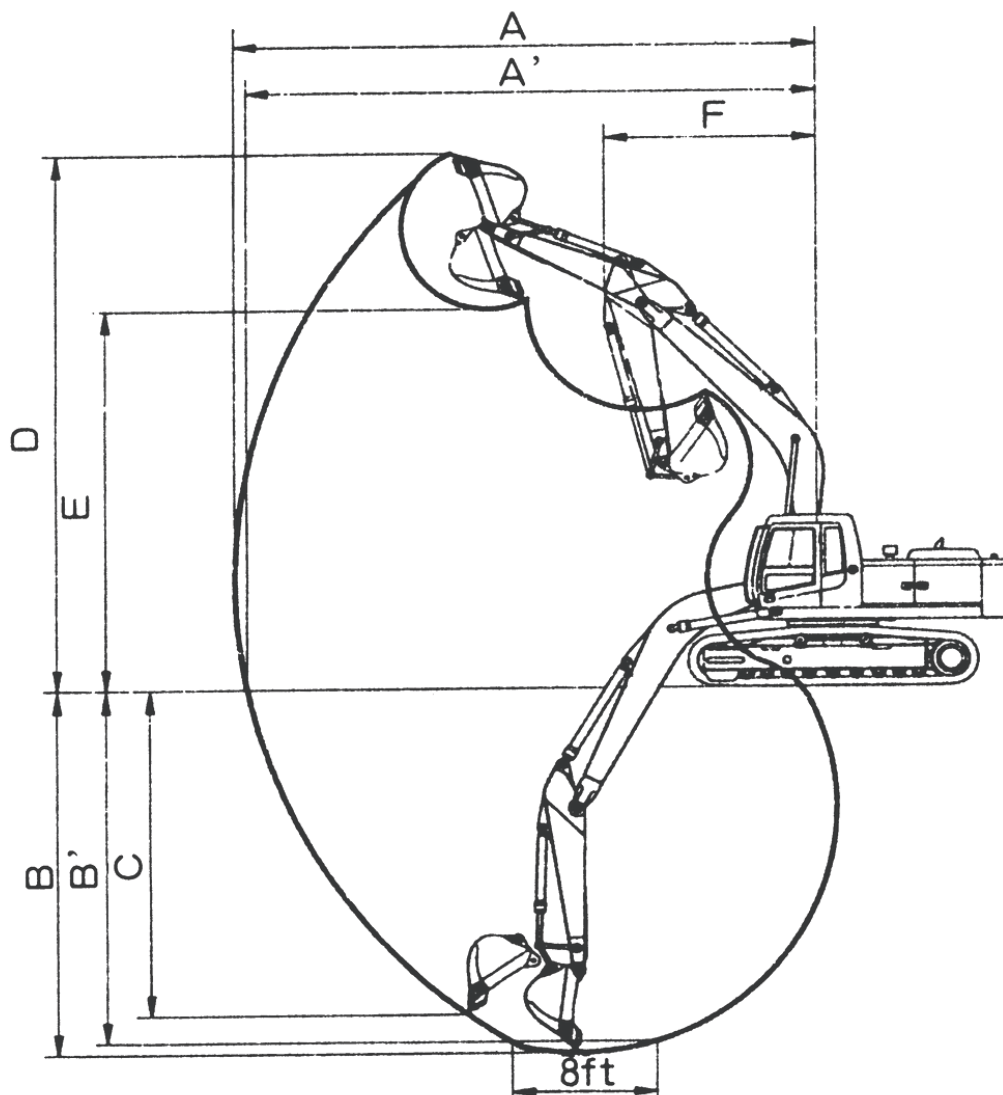

类别 ITEM		2.91m 斗杆 2.91m stick (mm)
		ZG3225LC-9C
最大挖掘半径 Maximum digging radius	A	9970
地面最大挖掘半径 Ground maximum digging radius	A'	9812
最大挖掘深度 Maximum digging depth	B	6707
地面最大挖掘深度 (2438mm 水平) Ground maximum digging depth	B'	6523
最大垂直挖掘深度	C	6107

Maximum vertical digging depth		
最大挖掘高度 Maximum digging height	D	9665
最大卸载高度 Maximum dumping height	E	6803
最小前部回转半径 Min. front turning radius	F	3560
铲斗挖掘力 Bucket digging force	ISO	137 KN
斗杆挖掘力 Stick digging force	ISO	102 KN

## 5. 发动机性能参数 Engine specifications

规格参数 Specifications	型号 Model		康明斯 Cummins 6BTAA5.9-C150
	型式 Type		六缸直列、四冲程涡轮增压 6-cylinder in-line, four-stroke turbocharger
	排放 Emission		国 II National II
	冷却方式 Cooling method		水冷 Water cooled
	缸径×行程 Bore diameter × stroke	mm	102×120
	气缸排量 Displacement	L	5.883
	额定功率 Rated power		112KW (150PS) @1950rpm
	最大扭矩 Max. torque	N.m	614N.m@1500rpm
	机油量 Engine oil capacity	L	24
	额定油耗率 Rated diesel consumption	g/ps.hr(rpm)	208g/ps.hr(1500rpm)
	起动马达 Starter		DENSO 24V/4.5KW
发电机 Generator		DELCO 24SI 28V/70A	

## 6. 主要部件配置 Main configuration

部件 \ 机型	ZG3225LC-9C
排放等级 Emission	国二 National II
发动机 Engine	东风康明斯 DONGFENG Cummins 6BTAA5.9-C150
主泵 Main pump	韩川液压 KAWASAKI K3V112DT
主控阀 Main valve	恒立液压 Germany InLine HVME270B
回转马达 Swing motor	恒立液压 Germany InLine HM5X130CHB 韩川液压 KAWASAKI F5X130CHB
行走马达 Travelling motor	现代液压 HYUNDAI HT21A
履带 Track	徐工 XCMG
空调 AC	斗源 DOOWON
回转支承 Slewing ring	马鞍山方圆 FANGYUAN
动臂 Arm	常林 CHANGLIN 5.68m
斗杆 Stick	常林聚科 JUKE 2.9m
铲斗 Bucket	常州华骏 HUAJUN 1.1m <sup>3</sup>
上下车架 Frame	常林 CHANGLIN